

LICENSING SUB-COMMITTEE

Date: Monday 20 March 2017
Time: 10.00 am
Venue: Bad Homburg Room, Civic Centre, Paris Street, Exeter

Members are invited to attend the above meeting to consider the items of business.

If you have an enquiry regarding any items on this agenda, please contact Howard Bassett, Democratic Services Officer (Committees) on 01392 265107 or email howard.bassett@exeter.gov.uk

Entry to the Civic Centre can be gained through the Customer Services Centre, Paris Street.

Membership -
Councillors Hannan, D Henson and Owen

Agenda

Part I: Items suggested for discussion with the press and public present

1 Appointment of Chair

To appoint a Chair for the meeting.

2 Declarations of Interest

Councillors are reminded of the need to declare any disclosable pecuniary interests that relate to business on the agenda and which have not already been included in the register of interests, before any discussion takes place on the item. Unless the interest is sensitive, you must also disclose the nature of the interest. In accordance with the Council's Code of Conduct, you must then leave the room and must not participate in any further discussion of the item. Councillors requiring clarification should seek the advice of the Monitoring Officer prior to the day of the meeting.

3 LOCAL GOVERNMENT (ACCESS TO INFORMATION) ACT 1985 EXCLUSION OF PRESS AND PUBLIC

It is considered unlikely that the Committee would wish to exclude the press and public during consideration of the items on this agenda. If, however, the Committee were to exclude the press and public, a resolution in the following form should be passed:

“RECOMMENDED that, under Section 100A (4) of the Local Government Act 1972, the press and public be excluded from the meeting for the particular item(s)

on the grounds that it (they) involve the likely disclosure of exempt information as defined in paragraph(s) of Part I of Schedule 12A of the Act.”

LOCAL GOVERNMENT (MISCELLANEOUS PROVISIONS) ACT 1976

4 Application for the grant of a new private hire vehicle licence over 4 years old

To consider the report of the Environmental Health and Licensing Manager.

(Pages 3 -
18)

LICENSING ACT 2003

5 Application to VARY the premises licence, Base & Barley, Unit 2, Portland House, Longbrook Street, Exeter, EX4 6AB.

To consider the report of the Environmental Health and Licensing Manager.

(Pages 19
- 44)

Details of the application may be found at <http://www.exeter.gov.uk/licensing>
Search the public register and the link is to the right of the page or may be viewed at the Licensing office between 09.00 and 16.00 Monday to Friday.

Individual reports on this agenda can be produced in large print on request to Democratic Services (Committees) on 01392 265107.

REPORT TO LICENSING (SUB) COMMITTEE

Time and Date of Hearing: 20 MARCH 2017 PART 1 Matter

Report of: Environmental Health and Licensing Manager

Type of Application: GRANT of a licence relating to a Private Hire vehicle over 4 years old.

Legislation: Local Government (Miscellaneous Provisions) Act 1976

Town Police Clauses Act 1847

Ward Application Refers to:

Not Applicable

Applicant: Mr M Hollis

Premises Address: Not Applicable

1. What is the report about?

- 1.1 An application has been received from Mr M HOLLIS, a licensed taxi driver seeking permission for the grant of a private hire vehicle licence for a vehicle which is over 4 years old at initial licensing. This is a matter that cannot be dealt with under delegated powers.

2. Are there any representations?

- 2.1 There is no provision in the legislation for anyone to submit representations relating to this kind of application.

3. Report details:

- 3.1 The vehicle, a Volkswagen Caddy registration mark NK10 CYV was first registered on 12 April 2010 making the vehicle over 4 years old so cannot be dealt with under delegated powers.
- 3.2 The recorded mileage of the vehicle at the time of the last MOT (10 February 2017) was 69451 miles. The MOT is attached as Appendix A. The vehicle when last inspected on the 10 February 2017 and was found to have no faults and suitable for immediate use. The mechanical inspection report is attached as Appendix B. The vehicle was inspected by a Licensing Officer on 2 February 2017 and the vehicle appeared to be in an excellent condition. Photographs are attached of the bodywork and the interior of the vehicle as Appendix C.

4. What are the legal aspects?

- 4.1 The Licensing Sub-Committee are required only to ensure that Public safety is not compromised by the granting of an extension of the licence. If they are satisfied that safety is reasonably assured they may grant the licence for a maximum of 12 months or such shorter period as they see as appropriate.

5. Recommendations:

- 5.1 The Licensing Sub-Committee are asked to determine the application having regard to current policy

Environmental Health and Licensing Manager

Local Government (Access to Information) Act 1972 (as amended)

Background papers used in compiling this report:-

None

Contact for enquires:

Democratic Services (Committees)

Room 2.3

01392 265275

N.B THIS IS NOT PART OF THE REPORT

LOCAL GOVERNMENT (MISCELLANEOUS PROVISIONS) ACT 1976

HACKNEY CARRIAGE AND PRIVATE HIRE VEHICLE / DRIVERS LICENCES

You are invited to appear before the Licensing Sub-Committee to speak in support of your application. A legal or other adviser may accompany you but may not appear instead of you.

Your Application

Depending on the circumstances, your application may be heard in part two of the Committee meeting procedures from which members of the public and press are excluded. You will be notified in advance if your application will be a part two matter, if you have not been advised of this, the hearing will be in the Public domain.

You or your adviser would be expected to respond to an officer's verbal introduction outlining the above report. You or your adviser may be asked questions and may be invited to ask questions if appropriate.

At the end of the hearing you will be asked to withdraw and the Committee will reach a decision. On conclusion of the decision making process you will then be recalled and the decision announced.



MOT Test Number
408927219565

Vehicle Registration Mark
NK10CYV

Vehicle Identification Number
WV2ZZZ2KZAX097106

Make
VOLKSWAGEN

Model
CADDY MAXI LIFE TDI 104

Colour
Silver

Issuer's Name
S. P. LOCK

Test Class
4

Country of Registration
Great Britain

Expiry Date
9 February 2018 (EIGHTEEN)

Issued
10 Feb 2017

Test Station
77882

Odometer Reading and History
10 2 2017: 69451 mi
23 9 2016: 59332 mi
13 7 2016: 54806 mi
15 7 2015: 23043 mi

Inspection Authority
CENTRAL GARAGE SERVICES EXETER LTD
31-35 OLD TIVERTON ROAD
EXETER
EX4 6LG
01392 428088

Additional Information
To preserve the anniversary of the expiry date, the earliest you can present your vehicle for test is 10 January 2018.

Signature of Issuer

Advisory Information
001 Shock absorber has a light misting of oil offside front [2.7.3]
002 Road wheel with a slightly distorted bead rim nearside front inner [4.2.A.1a]
003 (front brake discs worn)
004 (no density recorded in smoke test)

About this document

- 1 This document is a receipt style certificate telling you that an MOT Test pass result has been recorded in the Driver & Vehicle Standards Agency's (DVSA's) database of MOT Test results; this can be verified at www.gov.uk/check-mot-status.
 - 2 A test certificate relates only to the condition of the components examined at the time of test. It does not confirm the vehicle will remain roadworthy throughout the validity period of the certificate.
 - 3 Check carefully that the details are correct.
 - 4 Whilst advisory items listed above do not constitute MOT failure items, they are drawn to your attention for advice.
 - 5 For further information about this document, please visit www.gov.uk/getting-an-mot or contact DVSA on 0300 123 9000*.
- *Your call may be monitored or recorded for lawful purposes.

This page is intentionally left blank

APPENDIX B

Comprehensive Vehicle Inspection Report

Customer Details

Exeter Motor Works
Old Tiverton Road
Exeter

Report Date: 10/02/2017

Report No: 10136

Customer's contact details

Home:

Work: 01392 210739

Mobile: 07810825111

VEHICLE DETAILS

Make VOLKSWAGEN

Registration Number NK10 CYV

Model CADDY MAXI LIFE TDI

Colour SILVER

Vehicle Identity Number (VIN)

WV2ZZZ2KZAX097106

VIN Checked and confirmed
on vehicle
Yes X No

V5/Registration document
available and checked No

MOT Certificate available and
checked YES

Mileage reading In 69454
(Not guaranteed) Out 69451

MOT Expiry Date 09/02/18

Vehicle Excise Licence Expiry 01/01/18

Date of inspection 10/02//2017

Time of inspection 13:00

Location of vehicle Exeter Motor Works, Old Tiverton Road, Exeter.

Lighting Good

Weather. Good
(See notes)

Ramp available. Yes No
(See notes)

SECURITY CHECK

The vehicle identification number on this vehicle was checked and found to be **consistent** with the manufacturer's format.

SUMMARY REPORT

X **READY FOR USE** – No faults found, suitable for immediate use.

ADVISABLE REPAIRS ONLY – Suitable for immediate use but advisable repairs should be planned for.

ESSENTIAL AND ADVISABLE REPAIRS REQUIRED – Not suitable unless all essential repairs are undertaken and advisable repairs, if any are planned for.

UNSATISFACTORY – Vehicle has significant deficiencies, which are judged to be impractical or uneconomical to repair to a satisfactory standard.

Please read all pages of this report

KEY:

- S satisfactory
- R repainted
- = scratch
- X dent
- O corrosion
- C chip / rust
- P previous repairs

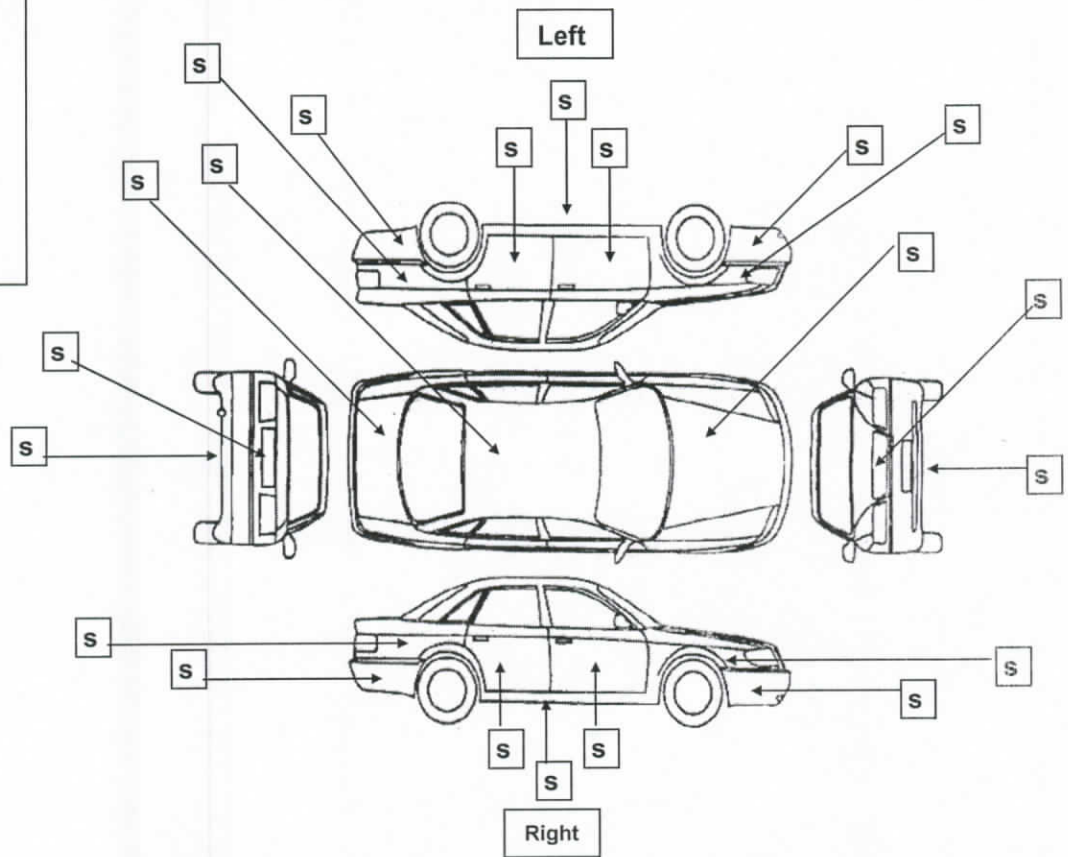

Minor blemishes, which are acceptable fair wear and tear for the vehicle's age, recorded mileage and type, are not recorded and you should satisfy yourself in this regard.

EVIDENCE OF BODYWORK REPAIRS	Yes	No X
BODYWORK CLEAN AND DRY	Yes X	No (See Notes)

Comments

The exterior body condition was good and commensurate with the vehicles age and recorded mileage.

KEY FOR POINTS ON FOLLOWING PAGES

- S Satisfactory for age and recorded mileage
 - Could not be checked
 - x Essential repair requiring immediate attention
 - A Advisable repair should be considered prior to purchase
 - N/A Not applicable
 - Y Yes
 - N No
- Please note: Right = Off side (O/S) and Left = Near side (N/S) as viewed from the driver's seat.

BODY EXTERIOR

1. Panel Condition / alignment	S	6. Door locks - operation	S	11. Mud flaps	S
2. Paintwork	S	7. Fuel filler cover and cap	S	12. Body panels	S
3. Exterior trim / grille	S	8. Soft top / Hard top (operation)	N/A	13. Bonnet catch	S
4. Glass	S	9. Body damage	A	14. Bonnet hinges	S
5. Bumpers / No plates – Ft / Rr	S	10. Corrosion	No	No	

ENGINE COMPARTMENT **PETROL** **DIESEL** **MULTI-FUEL** **No. of CYLINDERS: 4**

15. Coolant Level / Condition	S	22. Power Steering – oil level	S	29. Turbo / supercharger	--
16. Coolant leaks	No	23. Clutch Fluid	S	30. Fuel pump / pipes	S
17. Antifreeze *	S	24. Brake Fluid	S	31. Accelerator linkage	S
18. Radiator / Cap	S	25. Engine Oil level	S	32. Cold starting	--
19. Hoses / Pipes	S	26. External leaks (upper engine)	S	33. Fast idle (cold)	--
20. Drive Belts	--	27. Engine mountings	S	34. Noise level (cold)	--
21. Water Pump (Not visible)	--	28. Fuel Injection	S	35. Excess fumes / smoke	No

Note - To ensure future serviceability, it is important that the engine camshaft belt is replaced at intervals specified by the manufacturer. It is in your best interests you ensure that this is carried out. * Antifreeze only has a 2/3 year life span and requires its strength adjusting after this time or replacing as per manufacturers specifications.

ELECTRICAL / CONTROLS

36. Starting system / Ignition lock	S	41. Rear lights & No. plate lights	S	49. Instruments	S
37. Battery condition	S	42. Stop lights	S	50. Horn	S
38. Battery voltages:	S	43. Indicator/ Hazard lights	S	51. Radio/Cass/CD/Aerial	S
- Normal 13.11 volts	S	44. Reverse / Fog lights	S	52. Heater / Fan controls	S
- Starting 10.07 volts	S	45. Auxilliary lights	N/A	53. Air Con operation	S
- Charging 14.32 volts	S	46. Interior / Panel lights	S	54. Windows / Sun roof	S
39. Headlights	S	47. Mirrors (electric)	S	55. Wipers / Washers	S
40. Sidelights / running lights	S	48. Controls / Switches	S	56. Headlamp wash / wipe	N/A

Note - We are unable to verify dash panel light and switch back lighting operation due to the daylight conditions. Please note that switching them "on or off" only assesses electrical components. Accuracy of instruments cannot be assessed.

INTERIOR / LUGGAGE COMPARTMENT**NUMBER OF SEATS: 5**

57. Steering Wheel / Adjustment	S	64. Door seals / hinges	S	71. Rear parcel shelf / load cover	--
58. Seat upholstery	S	65. Interior sills	S	72. Boot / tailgate lock	S
59. Seat adjustment	S	66. Headlining / visors	S	73. Luggage area trim con	S
60. Seatbelts	S	67. Sun roof	N/A	74. Illumination light	S
61. Carpets / Mats	S	68. Dash panel (condition)	S	75. Tool kit	S
62. Door trim panels	S	69. Cigarette lighter	N/A	76. Hard / Soft top (condition)	N/A
63. Door fittings / operation	S	70. Mirrors (internal)	S	77. Tonneau cover	N/A

FRONT SUSPENSION / STEERING / UNDER FRAME

78. Engine underside leakage	No	83. Wheel hubs / bearings	S	88. Sub-frames mountings	S
79. Steering joints/ ball joints	S	84. Springs/suspension units	S	89. Suspension arms / mountings	S
80. Steering rack / box	S	85. Pipes / hoses	S	90. Tie bars / anti roll bars	S
81. Chassis members	S	86. Dampers (condition / leaks)	S	91. Corrosion protection	Yes
82. Power steering (operation)	S	87. Gaiters	S	92. Corrosion – floor/chassis	No

REAR SUSPENSION / UNDER FRAME

93. Springs/suspension bars	S	97. Location rods/fixings	N/A	101. Sub-frames/ mountings	S
94. Anti roll bar	S	98. Bump stops/gaiters	N/A	102. Chassis members	S
95. Dampers/bushes	S	99. Wheel hubs/bearings	S	103. Corrosion protection	Yes
96. Suspension arms/fixings	N/A	100. Pipes/hoses	N/A	104. Corrosion – floor/chassis	No

CLUTCH / TRANSMISSION**MANUAL** **AUTOMATIC** **MULTI-USE / 4x4**

105. Fluid / oil leaks	No	109. Casings	S	113. Backlash	S
106. Cables / adjustments	N/A	110. Mountings	S	114. Gaiters	S
107. Hydraulic system	S	111. Drive shaft assembly	S	115. Propshaft(s) / fittings	N/A
108. Linkage (wear)	S	112. Universal / sliding joints	S	116. Bearings / supports	N/A

EXHAUST SYSTEM

117. Manifold	S	120. Silencer(s)	S	123. System condition	S
118. Pipes	S	121. Heat shields / mountings	S		
119. Catalytic converter (s)	S	122. Joints / couplings	S		

FUEL SYSTEM

124. Tank	S	126. Fuel lines	S	128. Evidence of leaks	No
125. Tank fixings	S	127. Breather pipes	S		

BRAKES

129. Master cylinder security	S	132. Flexible hoses	S	135. Handbrake op / adjustment	S
130. Fluid leaks	No	133. Pipes / connections	S	136. Handbrake mechanism	S
131. Servo / power system	S	134. Discs / pads (if visible)	S	137. Pedal and pad / linkage	S

Note - If the vehicle is fitted with brake drums the internal parts including linings are not visible. Brake fluid should be replaced at the manufacturers specified intervals.

WHEELS AND TYRES Type: Steel

It is recommended tyres be replaced when the tread depth reaches 2mm. If uneven tyre wear is noted, this may indicate incorrect geometry, which can result in excessive and rapid tyre wear. A full steering and geometry check is recommended.

138. Wheel Rims	S				
139. Wheel Trims	S				
Tyres	Make	Size	Type / Construction	Min tread depth	
140. Front RH	Autogrip	205/55/16	Radial	4.5 mm	S
141. Front LH	Autogrip	205/55/16	Radial	5.3 mm	S
142. Rear LH	Autogrip	205/55/16	Radial	4.1 mm	S
143. Rear RH	Lanigator	205/55/16	Radial	6.8 mm	S
144. Spare	Contentental	125/70/18	Space saver type	3.2mm	S

145. ROAD TEST

The road test has been undertaken within the speed limits and prevailing traffic conditions in the locality of the inspection. If a road test has not been carried out, please refer to the engineer's comments page.

*If the vehicle is fitted with 4wd transmission then the systems have been checked for security, leakage and excessive noise. However, within the limitations of the road test the full functionality could not be checked.

Test Distance	3 Miles	Speed achieved up to 40 MPH			
146. Final drive operation / Noise level	S	153. Instrument /controls function	No	160. Road holding / stability	S
147. Gearbox operation / Noise level	S	154. Steering wheel alignment	S	161. General steering / handling	S
148. Engine performance	S	155. 4WD operation *	N/A	162. Footbrake operation	S
149. Engine noise	S	156. Clutch operation **	S	163. Hand/park brake operation	S
150. Excess smoke	No	157. Cooling fan operation	S	164. Suspension noise	No
151. Overheating evidence	No	158. Steering effort	S	165. Warning lights	S
152. Auto changes / kick-down	N/A	159. Hot restarting	S	166. Cruise control	S

** It should be carefully noted that the life expectancy of clutches is uncertain and difficult to predict, being dependant on owners driving style, vehicle operation and terrain. The fact that the clutch has not been identified as faulty/slipping/juddering/noisy on the report does not and should not be taken to imply that the clutch assembly will have a continuing life expectancy from the time of our check. They can begin to slip at any time.

FINAL CHECK

167. Oil leaks	No	168. Coolant leaks	No	169. Uneven tyre wear	No
----------------	----	--------------------	----	-----------------------	----

Report No: 10136

Vehicle documents and Inspection environment notes.

Engineer Indicate with "X" as applicable.

Registration Document (V5):

- No registration document was seen with the vehicle and you are advised to satisfy yourself that the vehicle identification number and engine number (where quoted) correspond to those shown on this report. Warning: **DO NOT BUY ANY VEHICLE WITHOUT A V5.**
- The V5/Registration Document shows _____ previous keeper(s), the last change of Keeper on _____.

Security:

- The Master Key was not available. Please ensure this is supplied if the vehicle is purchased.
- The engineer recommends that relevant spare and service keys be obtained prior to purchase.
- Obtain hand books and radio codes for vehicle prior to purchase as these were not seen in the vehicle.

M O T:

- As only a small amount of time is left on the MOT Certificate (less than 3 months) the engineer recommends a full year's MOT be obtained prior to purchase.
- A Full Year MOT Certificate has been seen with the vehicle.

Servicing:

- The service history seen, indicated that the last recorded service was carried out at _____ miles. No immediate servicing is necessary. Next service is due as per manufacturer's recommendations or as per the Vehicles Service indicator.
- The service history seen, indicated that the last recorded service was carried out on the _____ at _____ miles. Therefore the engineer would suggest a full service and brake inspection to the manufacturer recommendations prior to purchase, which may reveal further defects not apparent at this examination.
- No service documentation seen with this vehicle and therefore the engineer would recommend a full service and brake inspection to the manufacturer's recommendations prior to purchase, which may reveal further defects not apparent at this examination.

Inspection conditions notes:

- No vehicle hoist/ramp was available. A large trolley jack and stands were used in order to carry out underside checks. This limits the view of the underside. Some areas could not be fully seen. There *may* be further defects, which may be visible given clear access and view.
- The body/paintwork was wet/dirty/dusty this severely restricts inspection of the paintwork. Please note that there may be other defects present, which were not visible due to the obscured paintwork, but which may become visible once dry and clean.

Report No: 10136

Engineers Comments

The vehicle is considered overall to be a fair and reasonable example of the type, being in a generally reasonable condition and generally considered to be consistent with the type for the age and indicated recorded mileage in most areas.

The items listed as "could not be checked" (---) normally indicate items were obscured by covers/shields or other equipment.

The Water pump – Engine drive belt/chain - these items could not been fully examined, as covers, trims and other equipment obscure them.

The cooling system was pressure tested to 0.7 bars, no pressure loss was noted on the system or pressure cap. The antifreeze concentration was acceptable, but has deteriorated from its original strength and at the next routine service may need to be refreshed/replaced. It is advised that the coolant strength be checked again at the next routine service. Antifreeze only has a 2/3-year life and requires its strength adjusting after this time or replacing as per manufacturer's specifications.

The vehicle is fitted with vented front brake disc and pads, supported at the rear by a single arrangement. Although the visible brakes only show some signs of general serviceable wear, some deterioration is noted, which will need attention in the near future. It is strongly advised to remove all road wheels and examine the inner brake components, which are obscured on this vehicle prior to purchase, replacing any worn or badly corroded parts. It is probable that the front brakes at least, will need to be replaced at the next routine service.

The steering & suspension has been assessed to MOT standard. This allows for a degree of wear and deterioration of components without rendering them unserviceable. The extent of wear is not considered excessive at this juncture and unlikely to attract MOT failure.

The road test distance and or top speed was limited due to the general area/inspection location, and/or traffic levels and/or adverse weather conditions and/or lack of fuel when the vehicle was tested and driven. Comment cannot be made in these instances in relation to possible "high speed" or "sustained speed," related driving defects, which may become apparent at a later stage after any purchase due to these limiting conditions.

Essential Repairs

It is strongly advised that the essential defects are investigated and rectified prior to purchase.

Item	Comment
Additional Comments	
No vehicle hoist/ramp was available. A large trolley jack and stands were used in order to carry out underside checks. This limits the view of the underside somewhat. Some areas could not be fully seen. There may be further defects, which may be visible given clear underside access and view.	
The exhaust has been identified, as having limited life because, although there is no leakage present, there is some external corrosion present and the inside of the system, which may have significant deterioration, cannot be inspected internally.	
Please note that a service is recommended, this may reveal repairs or maintenance requirements that could not be identified due to the constraints of a visual and external examination of the vehicle carried out without the benefit of a vehicle hoist.	

Report No: 10136

This page is intentionally left blank

Appendix C.





This page is intentionally left blank

REPORT TO: LICENSING (SUB) COMMITTEE

Date of Hearing: 20 March 2017

Report of: Environmental Health and Licensing Manager

Type of Application: The application for the VARIATION of a premises licence in respect of THE BOOK COVER, UNIT 2, PORTLAND HOUSE, LONGBROOK STREET, EXETER, EX4 6AB under the relevant legislation.

Legislation: Licensing Act 2003

Ward Application Refers to: St James

Applicant: Stephen Keough

Premises Address: Unit 2, Portland House, Longbrook Street, Exeter, EX4 6AB.

1. What is the report about?

- 1.1 An application has been received from Stephen Keough, director for the VARIATION of a premises licence (copy attached). The proposed variation is for an extension to the current operating hours and to increase the hours for the sale of alcohol, late night refreshment and regulated entertainment on a Thursday, Friday and Saturday night. The current terminal hour in place is 00.00 for the sale of alcohol and late night refreshment and 00.30 for the regulated entertainment and opening hours.
- 1.2 The applicant has applied to increase the hours for the sale of alcohol and late night refreshment to 03.00 and 03.30 for the regulated entertainment and opening hours. The application is attached as Appendix A.
- 1.3 The non-standard timings applied for are as follows:
 - Regulated entertainment on 22, 23 and 24 December until 03.30
New Years Eve until 04.00.
 - Late night refreshment on 22, 23 and 24 December until 03.00
New Years Eve until 03.30.
 - Sale of alcohol on 22, 23 and 24 December until 03.00
New Years Eve until 03.30.
- 1.4 The Book Cover is situated in Exeter's city centre with other similar licensed premises situated close by such as The Old Firehouse, New North Road and Timepiece, Little Castle Street, both of which have a closing time Thursday to Saturday of 03.30. The applicant also manages two other licensed premises in Exeter such as Artgiano on 248 High Street, Exeter and The Terrace located in the Guildhall Queen Street area, both premises operate as late night venues with both premises closing at 02.00.

2. Are there any representations?

- 2.1 A Representation has been received from Cllr Pete Edwards with concerns with regard to public nuisance as the premises is located close to residential properties. The representation is attached as Appendix B.

3. Report details:

- 3.1 The application was advertised on the premises and in the local newspaper in line with above legislation.

4. What are the legal aspects?

- 4.1 The Council's constitution requires that all applications for Premises Licences that receive relevant representations shall be determined by a Licensing Sub-Committee.
- 4.2 The Licensing Sub-Committee are required to have regard to the Statement of Licensing Policy which states in part (paragraph 2.2) that in determining a licence application the Licensing Authority will consider each application on its merits. Chapters 9 and 10 of the Statement of Licensing Policy set out guidance in respect of the prevention of public nuisance and consideration of the impact of licensable activities.
- 4.3 The Licensing Sub-Committee are required to have regard to the Official Guidance issued under section 182 of the Licensing Act 2003 revised March 2015 is relevant. The official guidance relating to the prevention of public nuisance to which this committee must have regard, is included in the Yellow Committee hand books.
- 4.4 The Licensing Sub-Committee must have regard to the relevant representations made; the evidence provided in relation to the premises from the parties involved and the evidence it hears, in reaching its decision.
- 4.5 The Licensing Sub-Committee, having regard to the representation, must take such of the following steps, if any, as it considers appropriate for the promotion of the Licensing Objectives.
- to modify the conditions of the licence; and/or
 - to reject the whole or part of the application.

If the Licensing Sub-Committee considers that none of the above steps are appropriate for the promotion of the Licensing Objectives the Application shall be taken as granted.

5. Recommendations:

- 5.1 The Licensing Sub-Committee are required to identify what steps, if any, need to be taken to determine the application.

Environmental Health and Licensing Manager

Local Government (Access to Information) Act 1972 (as amended)

Background papers used in compiling this report:-
None

Contact for enquires:
Democratic Services (Committees)
Room 2.3
01392 265275

This page is intentionally left blank



Exeter
City Council

Licensing Authority
Exeter City Council
Civic Centre
Paris Street
Exeter
EX1 1RQ

Tel: 01392 265702
Fax: 01392 265844
e-mail: licensing.team@exeter.gov.uk

Licensing Act 2003

Premises Licence

EXE-P00507

Part 1 - Premises Details

POSTAL ADDRESS OF PREMISES, OR IF NONE, ORDNANCE SURVEY MAP REFERENCE OR DESCRIPTION

The Book Cover Exeter Ltd

Unit 2, Portland House, Longbrook Street, Exeter, Devon, EX4 6AB.

Telephone 01392 439933

WHERE THE LICENCE IS TIME LIMITED THE DATES

Not applicable

LICENSABLE ACTIVITIES AUTHORISED BY THE LICENCE

- any playing of recorded music
- provision of late night refreshment
- the supply of alcohol

THE TIMES THE LICENCE AUTHORISES THE CARRYING OUT OF LICENSABLE ACTIVITIES

Activity (and Area if applicable)	Description	Time From	Time To
F. Playing of recorded music (Indoors)	Monday to Saturday	7:00am	12:30am
	Sunday	9:00am	12:30am
I. Late night refreshment (Indoors)	Monday to Sunday	11:00pm	Midnight
J. Supply of alcohol for consumption ON and OFF the premises	Monday to Saturday	7:00am	Midnight
	Sunday	9:00am	Midnight

THE OPENING HOURS OF THE PREMISES

Description	Time From	Time To
Monday to Saturday	7:00am	12:30am
Sunday	9:00am	12:30am

WHERE THE LICENCE AUTHORISES SUPPLIES OF ALCOHOL WHETHER THESE ARE ON AND / OR OFF SUPPLIES

- J. Supply of alcohol for consumption ON and OFF the premises

Part 2

NAME, (REGISTERED) ADDRESS, TELEPHONE NUMBER AND EMAIL (WHERE RELEVANT) OF HOLDER OF PREMISES LICENCE

Base & Barley Limited
skeough@artigiano.uk.com

1 Colleton Crescent, Exeter, Devon, EX2 4DG.
Telephone 01392 439933





Exeter
City Council

Licensing Authority
Exeter City Council
Civic Centre
Paris Street
Exeter
EX1 1RQ

Tel: 01392 265702
Fax: 01392 265844

e-mail: licensing.team@exeter.gov.uk

Licensing Act 2003

Premises Licence

EXE-P00507

REGISTERED NUMBER OF HOLDER, FOR EXAMPLE COMPANY NUMBER, CHARITY NUMBER (WHERE APPLICABLE)

Base & Barley Limited

9702124

NAME, ADDRESS AND TELEPHONE NUMBER OF DESIGNATED PREMISES SUPERVISOR WHERE THE PREMISES LICENCE AUTHORISES THE SUPPLY OF ALCOHOL

Hannah Margaret PANKHURST

2 North Street, Heavitree, Exeter, Devon, EX1 2RH.
Telephone 01392 209543

PERSONAL LICENCE NUMBER AND ISSUING AUTHORITY OF PERSONAL LICENCE HELD BY DESIGNATED PREMISES SUPERVISOR WHERE THE PREMISES LICENCE AUTHORISES FOR THE SUPPLY OF ALCOHOL

Licence No. EXE-001513

Issued by Exeter

ANNEXES

ANNEXE 1 - MANDATORY CONDITIONS

There shall be no sale or supply of alcohol when there is no Designated Premises Supervisor (DPS) in respect of this premises licence or at a time when the said Premises Supervisor does not hold a personal licence or when his/her licence is suspended.

Every supply of alcohol under the premises licence must be made or authorised by a person who holds a personal licence.

Any person used to carry out a security activity must be licensed by the Security Industry Authority.

The responsible person must ensure that staff on relevant premises do not carry out, arrange or participate in any irresponsible promotions in relation to the premises. In this paragraph, an irresponsible promotion means any one or more of the following activities, or substantially similar activities, carried on for the purpose of encouraging the sale or supply of alcohol for consumption on the premises-

- (a) games or other activities which require or encourage, or are designed to require or encourage, individuals to-
 - (i) drink a quantity of alcohol within a time limit (other than to drink alcohol sold or supplied on the premises before the cessation of the period in which the responsible person is authorised to sell or supply alcohol), or
 - (ii) drink as much alcohol as possible (whether within a time limit or otherwise);
- (b) provision of unlimited or unspecified quantities of alcohol free or for a fixed or discounted fee to the public or to a group defined by a particular characteristic in a manner which carries a significant risk of undermining a licensing objective;
- (c) provision of free or discounted alcohol or any other thing as a prize to encourage or reward the purchase and consumption of alcohol over a period of 24 hours or less in a manner which carries a significant risk of undermining a licensing objective;
- (d) selling or supplying alcohol in association with promotional posters or flyers on, or in the vicinity of,





Licensing Act 2003

Premises Licence

EXE-P00507

ANNEXES continued ...

the premises which can reasonably be considered to condone, encourage or glamorise anti-social behaviour or to refer to the effects of drunkenness in any favourable manner;

- (e) dispensing alcohol directly by one person into the mouth of another (other than where that other person is unable to drink without assistance by reason of disability).

The responsible person must ensure that free potable water is provided on request to customers where it is reasonably available.

The premises licence holder or club premises certificate holder must ensure that an age verification policy is adopted in respect of the premises in relation to the sale or supply of alcohol. The designated premises supervisor in relation to the premises licence must ensure that the supply of alcohol at the premises is carried on in accordance with the age verification policy.

The policy must require individuals who appear to the responsible person to be under 18 years of age (or such older age as may be specified in the policy) to produce on request, before being served alcohol, identification bearing their photograph, date of birth and either-

- (a) a holographic mark, or
- (b) an ultraviolet feature.

The responsible person must ensure that-

- (a) where any of the following alcoholic drinks is sold or supplied for consumption on the premises (other than alcoholic drinks sold or supplied having been made up in advance ready for sale or supply in a securely closed container) it is available to customers in the following measures-
 - (i) beer or cider: ½ pint;
 - (ii) gin, rum, vodka or whisky: 25 ml or 35 ml; and
 - (iii) still wine in a glass: 125 ml;
- (b) these measures are displayed in a menu, price list or other printed material which is available to customers on the premises; and
- (c) where a customer does not in relation to a sale of alcohol specify the quantity of alcohol to be sold, the customer is made aware that these measures are available.

1. A relevant person shall ensure that no alcohol is sold or supplied for consumption on or off the premises for a price which is less than the permitted price.
2. For the purposes of the condition set out in paragraph 1-
 - (a) "duty" is to be construed in accordance with the Alcoholic Liquor Duties Act 1979
 - (b) "permitted price" is the price found by applying the formula-
$$P = D + (D \times V)$$
 where-
 - (i) P is the permitted price,
 - (ii) D is the amount of duty chargeable in relation to the alcohol as if the duty were charged on the date of the sale or supply of the alcohol, and
 - (iii) V is the rate of value added tax chargeable in relation to the alcohol as if the value added tax were charged on the date of the sale or supply of the alcohol;





Licensing Act 2003

Premises Licence

EXE-P00507

ANNEXES continued ...

- (c) "relevant person" means, in relation to premises in respect of which there is in force a premises licence-
- (i) the holder of the premises licence,
 - (ii) the designated premises supervisor (if any) in respect of such a licence, or
 - (iii) the personal licence holder who makes or authorises a supply of alcohol under such a licence;
- (d) "relevant person" means, in relation to premises in respect of which there is in force a club premises certificate, any member or officer of the club present on the premises in a capacity which enables the member or officer to prevent the supply in question; and
- (e) "valued added tax" means value added tax charged in accordance with the Value Added Tax Act 1994.
3. Where the permitted price given by Paragraph (b) of paragraph 2 would (apart from this paragraph) not be a whole number of pennies, the price given by that sub-paragraph shall be taken to be the price actually given by that sub-paragraph rounded up to the nearest penny.
4. (1) Sub-paragraph (2) applies where the permitted price given by Paragraph (b) of paragraph 2 on a day ("the first day") would be different from the permitted price on the next day ("the second day") as a result of a change to the rate of duty or value added tax.
(2) The permitted price which would apply on the first day applies to sales or supplies of alcohol which take place before the expiry of the period of 14 days beginning on the second day.

ANNEXE 2 - CONDITIONS CONSISTENT WITH THE OPERATING SCHEDULE

CCTV will be installed, maintained and operated to the satisfaction of the Chief Officer of Police.

CCTV recordings will be in colour and will be kept for 1 month.

The Licence holder will risk assess (and with agreement from the Police) as to whether Door Staff will be required at the Premises.

If Doorstaff are required, they will be required to remain at the Premises for 30 minutes after the Premises has closed to the Public.

Signage will be displayed at the entrance of the Premises advising customers that CCTV is in operation.

The Licence holder will be a member of the City of Exeter Licensees Association (CELA) and a nominated person will attend the CELA meetings.

Bag clips will be placed under the table at the Premises.

Signage will be displayed advising customers to be aware of potential theft inside the Premises.

No customer will be permitted inside the Premises with an open container of alcohol or soft drink.





Exeter
City Council

Licensing Authority
Exeter City Council
Civic Centre
Paris Street
Exeter
EX1 1RQ

Tel: 01392 265702
Fax: 01392 265844

e-mail: licensing.team@exeter.gov.uk

Licensing Act 2003

Premises Licence

EXE-P00507

ANNEXES continued ...

No customer will be permitted to leave the premises with an open container of alcohol or soft drink.

Staff training regarding the sale by retail of alcohol will be refreshed every three months, this staff training will be recorded.

All glass vessels will be made of toughend glass.

Signage will be displayed at the exit of the Premises advising customers to leave the Premises quietly.

The Premises will adopt the Challenge 21 age verification scheme.

Children under the age of 14 are only permitted to the Premises if they are accompanied by a responsible adult.

Base + Barley will only accept orders for alcohol and other goods where the delivery address is a residential address or a business address and not a public place

Alcohol will only be delivered to the person who placed the order and whose name appears on the credit/debit card

Challenge 25. If the driver considers the recipient of the alcohol to appear to be under 25 years of age, a recognised form of photographic identification will be requested and must be provided to prove that the recipient is at least 18 years of age before any alcohol is handed over

Delivery will also be refused if the driver believes the alcohol was purchased on behalf of another person who is not at least 18 years of age

There will be a minimum age of 18 years for all drivers delivering alcohol

ANNEXE 3 - CONDITIONS ATTACHED AFTER A HEARING

None.

ANNEXE 4 - PLANS

Copy attached to Licence.





Exeter
City Council

Licensing Authority
Exeter City Council
Civic Centre
Paris Street
Exeter
EX1 1RQ

Tel: 01392 265702
Fax: 01392 265844
e-mail: licensing.team@exeter.gov.uk

Licensing Act 2003

Premises Licence

EXE-P00507

ANNEXES continued ...





Exeter
City Council

Licensing Authority
Exeter City Council
Civic Centre
Paris Street
Exeter
EX1 1RQ

Tel: 01392 265702
Fax: 01392 265844
e-mail: licensing.team@exeter.gov.uk

Licensing Act 2003

Premises Licence Summary

EXE-P00507

Premises Details

POSTAL ADDRESS OF PREMISES, OR IF NONE, ORDNANCE SURVEY MAP REFERENCE OR DESCRIPTION

The Book Cover Exeter Ltd

Unit 2, Portland House, Longbrook Street, Exeter, Devon, EX4 6AB.

Telephone 01392 439933

WHERE THE LICENCE IS TIME LIMITED THE DATES

Not applicable

LICENSABLE ACTIVITIES AUTHORISED BY THE LICENCE

- any playing of recorded music
- provision of late night refreshment
- the supply of alcohol

THE TIMES THE LICENCE AUTHORISES THE CARRYING OUT OF LICENSABLE ACTIVITIES

Activity (and Area if applicable)	Description	Time From	Time To
F. Playing of recorded music (Indoors)	Monday to Saturday	7:00am	12:30am
	Sunday	9:00am	12:30am
I. Late night refreshment (Indoors)	Monday to Sunday	11:00pm	Midnight
J. Supply of alcohol for consumption ON and OFF the premises	Monday to Saturday	7:00am	Midnight
	Sunday	9:00am	Midnight

THE OPENING HOURS OF THE PREMISES

Description	Time From	Time To
Monday to Saturday	7:00am	12:30am
Sunday	9:00am	12:30am

WHERE THE LICENCE AUTHORISES SUPPLIES OF ALCOHOL WHETHER THESE ARE ON AND / OR OFF SUPPLIES

- J. Supply of alcohol for consumption ON and OFF the premises

NAME, (REGISTERED) ADDRESS OF HOLDER OF PREMISES LICENCE

Base & Barley Limited

1 Colleton Crescent, Exeter, Devon, EX2 4DG.





Exeter
City Council

Licensing Authority
Exeter City Council
Civic Centre
Paris Street
Exeter
EX1 1RQ

Tel: 01392 265702
Fax: 01392 265844
e-mail: licensing.team@exeter.gov.uk

Licensing Act 2003

Premises Licence Summary

EXE-P00507

REGISTERED NUMBER OF HOLDER, FOR EXAMPLE COMPANY NUMBER, CHARITY NUMBER (WHERE APPLICABLE)

Base & Barley Limited

9702124

NAME OF DESIGNATED PREMISES SUPERVISOR WHERE THE PREMISES LICENCE AUTHORISES THE SUPPLY OF ALCOHOL

Hannah Margaret PANKHURST

STATE WHETHER ACCESS TO THE PREMISES BY CHILDREN IS RESTRICTED OR PROHIBITED

Restricted by the Licensing Act 2003



APPENDIX A

419430
21/2/17
£315



Exeter
Application to vary a premises licence
Licensing Act 2003

For help contact
licensing.team@exeter.gov.uk
Telephone: 01392 265702

* required information

Section 1 of 17

You can save the form at any time and resume it later. You do not need to be logged in when you resume.

System reference This is the unique reference for this application generated by the system.

Your reference You can put what you want here to help you track applications if you make lots of them. It is passed to the authority.

Are you an agent acting on behalf of the applicant?
 Yes No

Put "no" if you are applying on your own behalf or on behalf of a business you own or work for.

Applicant Details

* First name

* Family name

* E-mail

Main telephone number Include country code.

Other telephone number

Indicate here if you would prefer not to be contacted by telephone

Are you:

Applying as a business or organisation, including as a sole trader

Applying as an individual

A sole trader is a business owned by one person without any special legal structure. Applying as an individual means you are applying so you can be employed, or for some other personal reason, such as following a hobby.

Applicant Business

Is your business registered in the UK with Companies House? Yes No

Registration number

Business name If your business is registered, use its registered name.

VAT number Put "none" if you are not registered for VAT.

Legal status

Note: completing the Applicant Business section is optional in this form.

Continued from previous page...

Your position in the business

Home country

The country where the headquarters of your business is located.

Registered Address

Address registered with Companies House.

Building number or name

Street

District

City or town

County or administrative area

Postcode

Country

Section 2 of 17

APPLICATION DETAILS

This application cannot be used to vary the licence so as to extend the period for which the licence has effect or to vary substantially the premises to which it relates. If you wish to make that type of change to the premises licence, you should make a new premises licence application under section 17 of the Licensing Act 2003.

I/we, as named in section 1, being the premises licence holder, apply to vary a premises licence under section 34 of the Licensing Act 2003 for the premises described in section 2 below.

* Premises Licence Number

Are you able to provide a postal address, OS map reference or description of the premises?

- Address OS map reference Description

Postal Address Of Premises

Building number or name

Street

District

City or town

County or administrative area

Postcode

Country

Premises Contact Details

Telephone number

Continued from previous page...

Non-domestic rateable value of premises (£)

54,000

Section 3 of 17

VARIATION

Do you want the proposed variation to have effect as soon as possible?

Yes No

Do you want the proposed variation to have effect in relation to the introduction of the late night levy?

Yes No

You do not have to pay a fee if the only purpose of the variation for which you are applying is to avoid becoming liable to the late night levy.

If your proposed variation would mean that 5,000 or more people are expected to attend the premises at any one time, state the number expected to attend

Describe Briefly The Nature Of The Proposed Variation

Describe the premises. For example the type of premises, its general situation and layout and any other information which could be relevant to the licensing objectives. Where your application includes off-supplies of alcohol and you intend to provide a place for consumption of these off-supplies, you must include a description of where the place will be and its proximity to the premises.

We would like to extend our hours for the supply of alcohol and late night refreshment

Section 4 of 17

PROVISION OF PLAYS

Will the schedule to provide plays be subject to change if this application to vary is successful?

Yes No

Section 5 of 17

PROVISION OF FILMS

Will the schedule to provide films be subject to change if this application to vary is successful?

Yes No

Section 6 of 17

PROVISION OF INDOOR SPORTING EVENTS

Will the schedule to provide indoor sporting events be subject to change if this application to vary is successful?

Section 7 of 17**PROVISION OF BOXING OR WRESTLING ENTERTAINMENTS**

Will the schedule to provide boxing or wrestling entertainments be subject to change if this application to vary is successful?

Yes No

Section 8 of 17**PROVISION OF LIVE MUSIC**

Will the schedule to provide live music be subject to change if this application to vary is successful?

Yes No

Section 9 of 17**PROVISION OF RECORDED MUSIC**

Will the schedule to provide recorded music be subject to change if this application to vary is successful?

Yes No

Standard Days And Timings

MONDAY

Start End Start End

Provide timings in 24 hour clock (e.g., 16:00) and only give details for the days of the week when you intend the premises to be used for the activity.

TUESDAY

Start End Start End

WEDNESDAY

Start End Start End

THURSDAY

Start End Start End

FRIDAY

Start End Start End

SATURDAY

Start End Start End

Continued from previous page...

SUNDAY

Start

End

Start

End

Will the playing of recorded music take place indoors or outdoors or both?

- Indoors Outdoors Both

Where taking place in a building or other structure select as appropriate. Indoors may include a tent.

State type of activity to be authorised, if not already stated, and give relevant further details, for example (but not exclusively) whether or not music will be amplified or unamplified.

The music will be played at the volume levels one might expect to find in a coffee shop, bar, restaurant

State any seasonal variations for playing recorded music.

For example (but not exclusively) where the activity will occur on additional days during the summer months.

Non-standard timings. Where the premises will be used for the playing of recorded music at different times from those listed above, list below.

For example (but not exclusively), where you wish the activity to go on longer on a particular day e.g. Christmas Eve.

On 22nd, 23rd and 24th December we would like to play recorded music until 03:30 the following day
On New Year's Eve we would like to play recorded music until 04:00 the following day.

Section 10 of 17

PROVISION OF PERFORMANCES OF DANCE

Will the schedule to provide performances of dance be subject to change if this application to vary is successful?

- Yes No

Section 11 of 17

PROVISION OF ANYTHING OF A SIMILAR DESCRIPTION TO LIVE MUSIC, RECORDED MUSIC OR PERFORMANCES OF DANCE

Will the schedule to provide anything similar to live music, recorded music or performances of dance be subject to change if this application to vary is successful?

- Yes No

Section 12 of 17

PROVISION OF LATE NIGHT REFRESHMENT

Continued from previous page...

Will the schedule to provide late night refreshment be subject to change if this application to vary is successful?

- Yes No

Standard Days And Timings

MONDAY

Start

End

Start

End

Provide timings in 24 hour clock (e.g., 16:00) and only give details for the days of the week when you intend the premises to be used for the activity.

TUESDAY

Start

End

Start

End

WEDNESDAY

Start

End

Start

End

THURSDAY

Start

End

Start

End

FRIDAY

Start

End

Start

End

SATURDAY

Start

End

Start

End

SUNDAY

Start

End

Start

End

Will the provision of late night refreshment take place indoors or outdoors or both?

- Indoors Outdoors Both

Where taking place in a building or other structure select as appropriate. Indoors may include a tent.

State type of activity to be authorised, if not already stated, and give relevant further details, for example (but not exclusively) whether or not music will be amplified or unamplified.

We would like to serve late night refreshments such as coffees, teas and hot and cold snacks and light meals

Continued from previous page...

State any seasonal variations.

For example (but not exclusively) where the activity will occur on additional days during the summer months.

Non standard timings. Where the premises will be used for the provision of late night refreshment at different times from those listed above, list below.

For example (but not exclusively), where you wish the activity to go on longer on a particular day e.g. Christmas Eve.

On 22nd, 23rd and 24th December we would like to serve late night refreshments until 03:00 the following day

On New Year's Eve we would like to serve late night refreshments until 03:30 the following day.

Section 13 of 17

SUPPLY OF ALCOHOL

Will the schedule to supply alcohol be subject to change if this application to vary is successful?

- Yes No

Standard Days And Timings

MONDAY

Start

End

Start

End

Provide timings in 24 hour clock (e.g., 16:00) and only give details for the days of the week when you intend the premises to be used for the activity.

TUESDAY

Start

End

Start

End

WEDNESDAY

Start

End

Start

End

THURSDAY

Start

End

Start

End

FRIDAY

Start

End

Start

End

Continued from previous page...

SATURDAY

Start

End

Start

End

SUNDAY

Start

End

Start

End

Will the sale of alcohol be for consumption?

- On the premises Off the premises Both

If the sale of alcohol is for consumption on the premises select on, if the sale of alcohol is for consumption away from the premises select off. If the sale of alcohol is for consumption on the premises and away from the premises select both.

State any seasonal variations.

For example (but not exclusively) where the activity will occur on additional days during the summer months.

Non-standard timings. Where the premises will be used for the supply of alcohol at different times from those listed above, list below.

For example (but not exclusively), where you wish the activity to go on longer on a particular day e.g. Christmas Eve.

On 22nd, 23rd and 24th December we would like to serve alcohol until 03:00 the following day

On New Year's Eve we would like to serve alcohol until 03:30 the following day.

Section 14 of 17

ADULT ENTERTAINMENT

Highlight any adult entertainment or services, activities, or other entertainment or matters ancillary to the use of the premises that may give rise to concern in respect of children.

Provide information about anything intended to occur at the premises or ancillary to the use of the premises which may give rise to concern in respect of children, regardless of whether you intend children to have access to the premises, for example (but not exclusively) nudity or semi-nudity, films for restricted age groups etc gambling machines etc.

None

Section 15 of 17

HOURS PREMISES ARE OPEN TO THE PUBLIC

Standard Days And Timings

Continued from previous page...

MONDAY

Start

End

Start

End

Provide timings in 24 hour clock (e.g., 16:00) and only give details for the days of the week when you intend the premises to be used for the activity.

TUESDAY

Start

End

Start

End

WEDNESDAY

Start

End

Start

End

THURSDAY

Start

End

Start

End

FRIDAY

Start

End

Start

End

SATURDAY

Start

End

Start

End

SUNDAY

Start

End

Start

End

State any seasonal variations.

For example (but not exclusively) where the activity will occur on additional days during the summer months.

Non standard timings. Where you intend to use the premises to be open to the members and guests at different times from those listed above, list below.

For example (but not exclusively), where you wish the activity to go on longer on a particular day e.g. Christmas Eve.

On 22nd, 23rd and 24th December we would like to remain open until 03:30 the following day

On New Year's Eve we would like to remain open until 04:00 the following day.

Continued from previous page...

Identify those conditions currently imposed on the licence which you believe could be removed as a consequence of the proposed variation you are seeking.

- I have enclosed the premises licence
- I have enclosed the relevant part of the premises licence

Reasons why I have failed to enclose the premises licence or relevant part of premises licence.

Section 16 of 17

LICENSING OBJECTIVES

Describe the steps you intend to take to promote the four licensing objectives:

a) General – all four licensing objectives (b,c,d,e)

List here steps you will take to promote all four licensing objectives together.

Our aim is to provide craft beers and fine wines in a pleasant and relaxed environment We are gearing the environment towards the more discerning customer and we will take steps to stop situations arising which would make that experience unpleasant or unsafe for our customers, our staff or our neighbours. There will be no adult entertainment.

All staff involved in the sale of alcohol will receive training and a record will be maintained on the premises of that training and made available to the Police or Licensing Authority on request.

The services of registered door supervisors will be employed when we are serving alcohol after midnight.

b) The prevention of crime and disorder

A digitally recorded CCTV system shall continually record the customer areas of the premises whilst the premises are open to the public and recordings shall be kept for a minimum of 28 days with time and date stamping. Data recordings shall be made immediately available to an authorised officer of Exeter City Council or a police officer, together with facilities for viewing upon request. Recorded images shall be of such a quality as to be able to identify the recorded person.

Table hooks will be used for customers to put handbags and coats safely to avoid theft. We operate an Under 21 Challenge policy.

Private functions must be pre-booked and diarised. This diary will be made available to the Police or Licensing Authority on request.

Signs will be displayed on the windows and at the tills advising customers to be aware of thieves, our Under 21 Challenge policy and to respect our neighbours by keeping the noise down when leaving the premises (especially at night).

The services of registered door supervisors will be employed when we are serving alcohol after midnight.

c) Public safety

All glasses used will be of a suitable safety standard (e.g. toughened).

Continued from previous page...

A CCTV system will be installed and maintained at the premises. The images will be of evidential standard and recordings will be kept for 31 days and made available to the Police and Licensing Authority upon reasonable request.

The services of registered door supervisors will be employed when we are serving alcohol after midnight.

d) The prevention of public nuisance

We will monitor noise levels and take action to minimise the noise if it appears to become an issue.

We only sell premium products and they are not cheap. We do not attract people who are out to get drunk. Our record in existing outlets is exemplary. There has not been a single incident of any kind anywhere.

Alcohol sold for consumption off the premises will be in sealed containers. No single bottles of beer shall be sold for takeaway off the premises.

The services of registered door supervisors will be employed when we are serving alcohol after midnight.

Signs will be displayed at entrances / exits requesting that customers leave quietly.

e) The protection of children from harm

We shall at all times operate a Challenge 21 policy to prevent any customers who attempt to purchase alcohol and who appear to the staff member to be under the age of 21 years from making such a purchase without having first provided identification. Only a valid British driver's licence showing a photograph of the person, a valid passport or a nationally approved proof of age card showing the 'Pass' hologram (or any other similarly nationally recognised scheme) are to be accepted as identification. A record will be kept of incidences on which supply has been refused on the basis of age.

Notices advertising the Challenge 21 policy shall be displayed in prominent positions on the premises

Children who appear to be under the age of 14 years will only be allowed on the premises after 6pm if accompanied by an adult.

Section 17 of 17

PAYMENT DETAILS

This fee must be paid to the authority. If you complete the application online, you must pay it by debit or credit card.

Variation Fees are determined by the non domestic rateable value of the premises.

To find out a premises non domestic rateable value go to the Valuation Office Agency site at http://www.voa.gov.uk/business_rates/index.htm

Band A - No RV to £4300	£100.00
Band B - £4301 to £33000	£190.00
Band C - £33001 to £8700	£315.00
Band D - £87001 to £12500	£450.00*
Band E - £125001 and over	£635.00*

*If the premises rateable value is in Bands D or E and the premises is primarily used for the consumption of alcohol on the premises then you are required to pay a higher fee

Band D - £87001 to £12500	£900.00
Band E - £125001 and over	£1,905.00

If you own a large premise you are subject to additional fees based upon the number in attendance at any one time

Capacity 5000-9999	£1,000.00
Capacity 10000 -14999	£2,000.00
Capacity 15000-19999	£4,000.00

Continued from previous page...

Capacity 20000-29999	£8,000.00
Capacity 30000-39000	£16,000.00
Capacity 40000-49999	£24,000.00
Capacity 50000-59999	£32,000.00
Capacity 60000-69999	£40,000.00
Capacity 70000-79999	£48,000.00
Capacity 80000-89999	£56,000.00
Capacity 90000 and over	£64,000.00

* Fee amount (£)

ATTACHMENTS

AUTHORITY POSTAL ADDRESS

Address

Building number or name

Street

District

City or town

County or administrative area

Postcode

Country

DECLARATION

* I/we understand it is an offence, liable on conviction to a fine up to level 5 on the standard scale, under section 158 of the licensing act 2003, to make a false statement in or in connection with this application.

Ticking this box indicates you have read and understood the above declaration

This section should be completed by the applicant, unless you answered "Yes" to the question "Are you an agent acting on behalf of the applicant?"

* Full name

* Capacity

Date (dd/mm/yyyy)

Once you're finished you need to do the following:

1. Save this form to your computer by clicking file/save as...
2. Go back to <https://www.gov.uk/apply-for-a-licence/premises-licence/exeter/change-1> to upload this file and continue with your application.

Don't forget to make sure you have all your supporting documentation to hand.

IT IS AN OFFENCE, LIABLE ON SUMMARY CONVICTION TO A FINE NOT EXCEEDING LEVEL 5 ON THE STANDARD SCALE, UNDER SECTION 158 OF THE LICENSING ACT 2003, TO MAKE A FALSE STATEMENT IN OR IN CONNECTION WITH THIS APPLICATION

Appendix B.

Received via email on 10 February 2017

Caroline,

I have concerns about the late opening that is being proposed with this application seeing that it is in a residential area.

Cllr Pete Edwards.

This page is intentionally left blank